

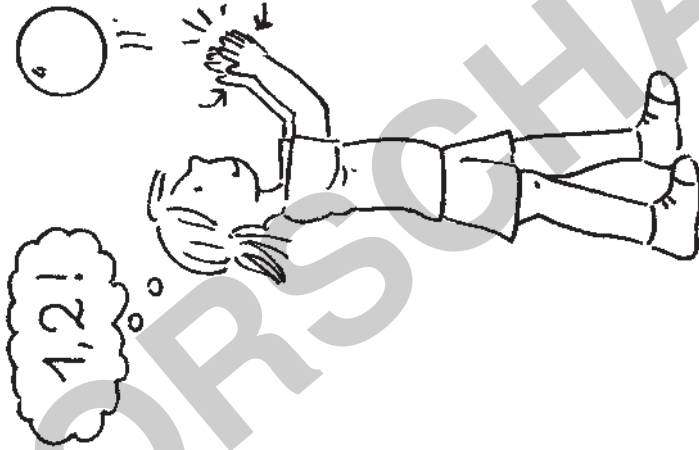

Du brauchst:

- 1 Ball  je Kind



Wirf den Ball so hoch, wie du kannst.
Klatsche 2x in die Hände und fange den Ball.

einfacher 

Wirf den Ball hoch.
Fange ihn.

schwieriger   

Wirf den Ball so hoch, wie du kannst.
Drehe dich um oder setze dich auf den Boden.
Fange den Ball.

Station 3

Schwingendes Seil



Du brauchst:

- 1 langes Seil



Wie viele Sprünge schaffst du?

einfacher ☆

schwieriger ☆☆☆

Dein Partner dreht das Seil am Boden im Kreis.
Springe über das Seil.

Können ihr zu zweit springen?



Du brauchst:

- 1 Reifen  je Kind

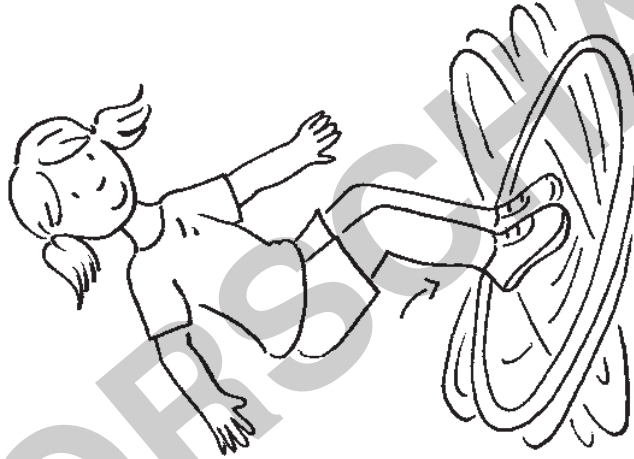

**Zwirble den Reifen.
Laufe um den Reifen
herum. Springe in den
Reifen, bevor er liegt.**

einfacher ★

Zwirble den Reifen.

Springe in den Reifen, bevor er liegt.

schwieriger ★ ★ ★

Zwirble den Reifen.

Laufe zur Hallenwand und klatsche sie ab.
Springe in den Reifen, bevor er liegt.

Pantomime (Kärtchen)

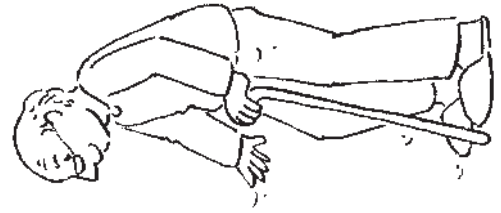
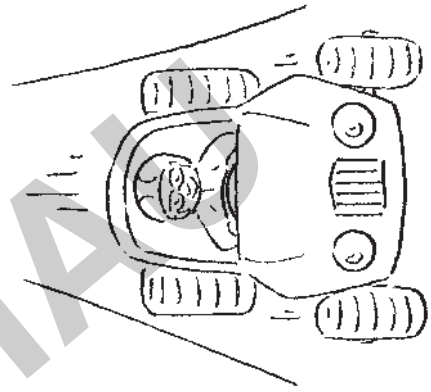
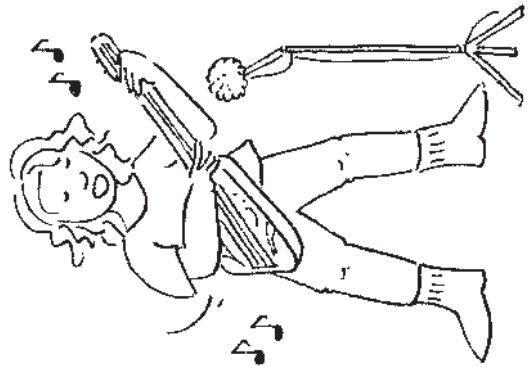
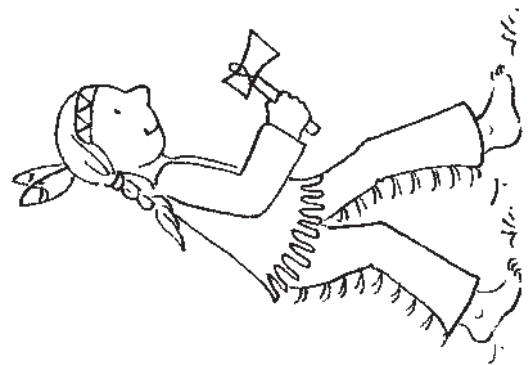
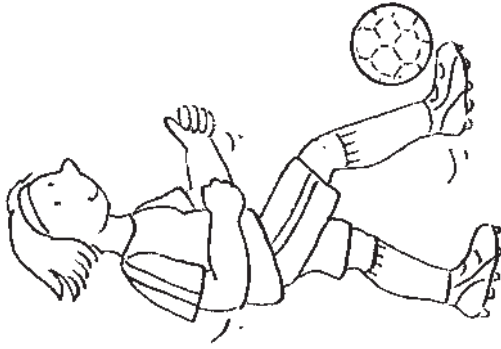
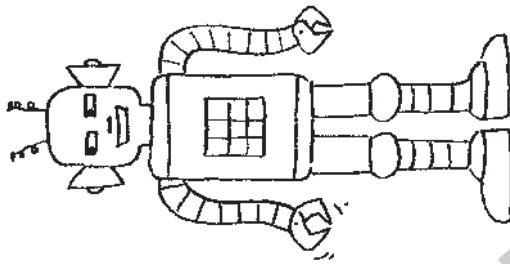
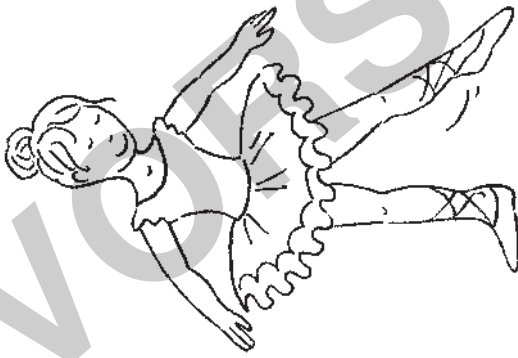

Station

1

Station

2

VORSCHAU

